



Palm & Tree Anchoring Systems

U.S. Patent US 6,389,743 B1

P.O. Box 596

Spicewood, Tx. 78669

Of: 713.665.7256

www.hciglobal.com

gl@hciglobal.com

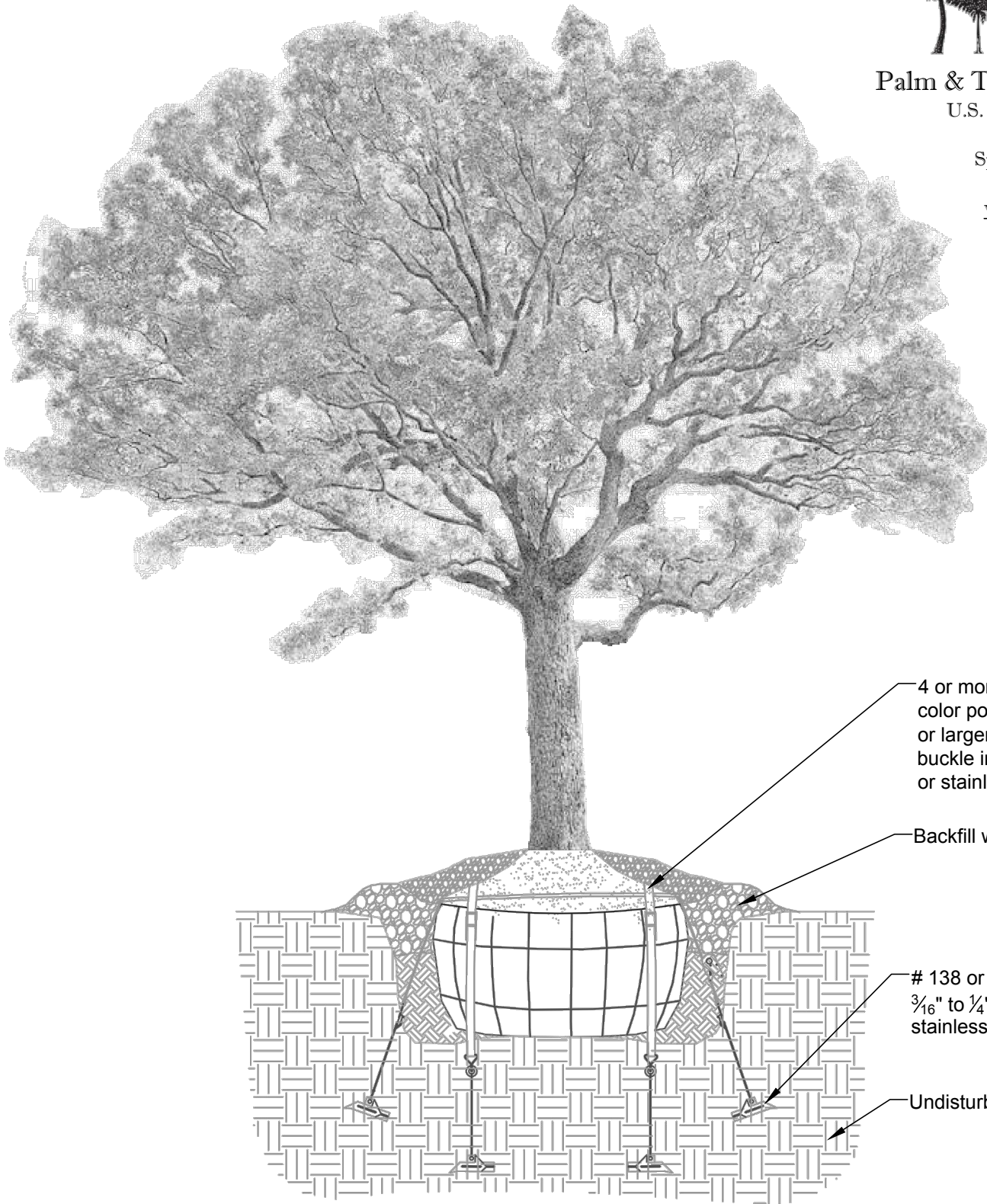

TYPICAL OAK TREE

NOT TO SCALE

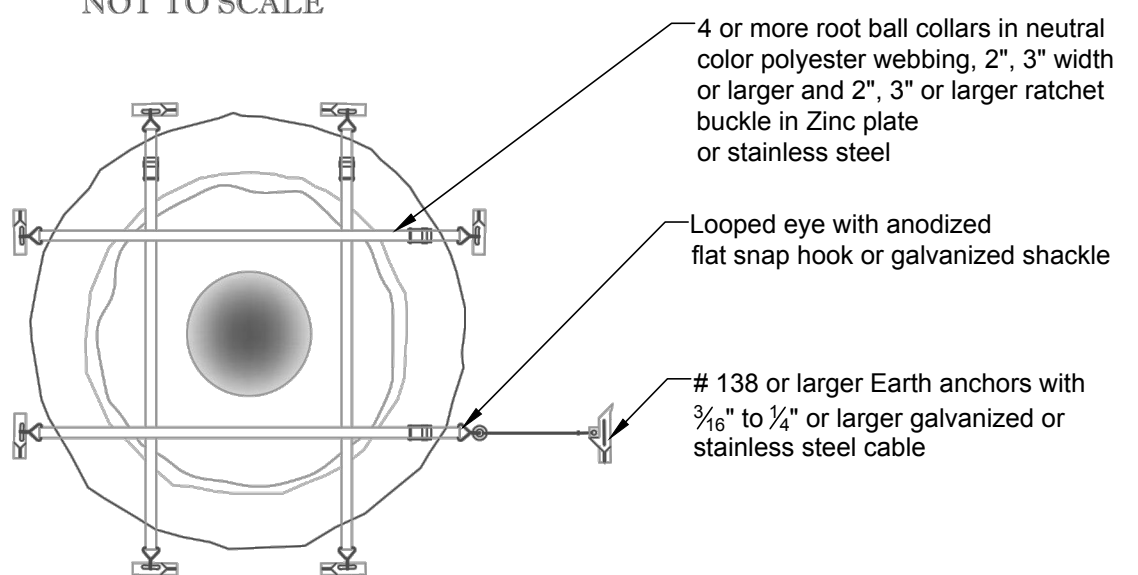

OASIS ROOT MASS EARTH ANCHOR SYSTEM

U.S. Patent No. US 6,389,743 B1

DETAIL 26-U.S.